



POLISHING MACHINES

bench and column type

Power ratings from
Hp 1 to Hp 5 for brushes
diameter 200 mm to 400 mm

DESIGNED FOR INDUSTRIAL USE,
THEY ARE USED FOR POLISHING OPERATIONS.
IT IS POSSIBLE TO MOUNT BRUSHES WITH
DIFFERENT CHARACTERISTICS
(FABRIC, METAL WIRES, ETC.).

Technical features:

- Cast iron body, to ensure maximum stability and the absence of vibrations
- Mechanical components manufactured and machined in-house to guarantee Stefani's Made in Italy quality
- Fully rectified and dynamically balanced brush shaft
- Clamping flanges turned from solid to totally eliminate the risk of vibrations
- Safety guards made of high-strength sheet steel, equipped with suction connections
- Equipped with start/stop/emergency buttons and anti-reset function
- Compliant with EC standards

Optional:

- Cast-iron column
- 24-Volt electrical equipment (in cases not provided for by regulations)
- Exhauster

On request:

- Speed 1400/2800 rpm
- Electronic speed variator
- Motor brake
- Increased shaft length





Via Villorosi 71 - 20029 Turbigo MI
P.IVA e C.F. 11336420150
Tel. +39.0331.899144
Fax +39.0331.890178
info@stefanisrl.it - www.stefanisrl.it

POLISHING MACHINES

bench and column type

Power ratings from
Hp 1 to Hp 5 for brushes
diameter 200 mm to 400 mm

POLISHING MACHINES PP TECHNICAL DATA

MODEL	Hp	Kw				Kg	
						bench type	column type
PP/3T	1	0,75	3-phase – 50 Hz	2800	200x25 f.20	33	57
PP/4T	1	0,75	3-phase – 50 Hz	2800	200x25 f.20	38	69
PP/5T	1,5	1,12	3-phase – 50 Hz	2800	200x30 f.20	43	74
PP/6T	1,5	1,12	3-phase – 50 Hz	2800	250x30 f.25	61	107
PP/7T	2	1,49	3-phase – 50 Hz	2800	250x35 f.25	66	112
PP/8T	3	2,24	3-phase – 50 Hz	2800	300x30 f.25	82	128
PP/9T	3	2,24	3-phase – 50 Hz	2800	300x35 f.25	97	152
PP/10T	4	2,98	3-phase – 50 Hz	2800	300x40 f.25	112	167
PP/11T	5	3,73	3-phase – 50 Hz	2800	400x40 f.25	133	188

PP/3M	1	0,75	1-phase – 50 Hz	2800	200x25 f.20	33	57
PP/4M	1	0,75	1-phase – 50 Hz	2800	200x25 f.20	38	69
PP/5M	1,5	1,12	1-phase – 50 Hz	2800	200x30 f.20	43	74

OVERALL DIMENSIONS - POLISERS, BENCH AND COLUMN TYPE

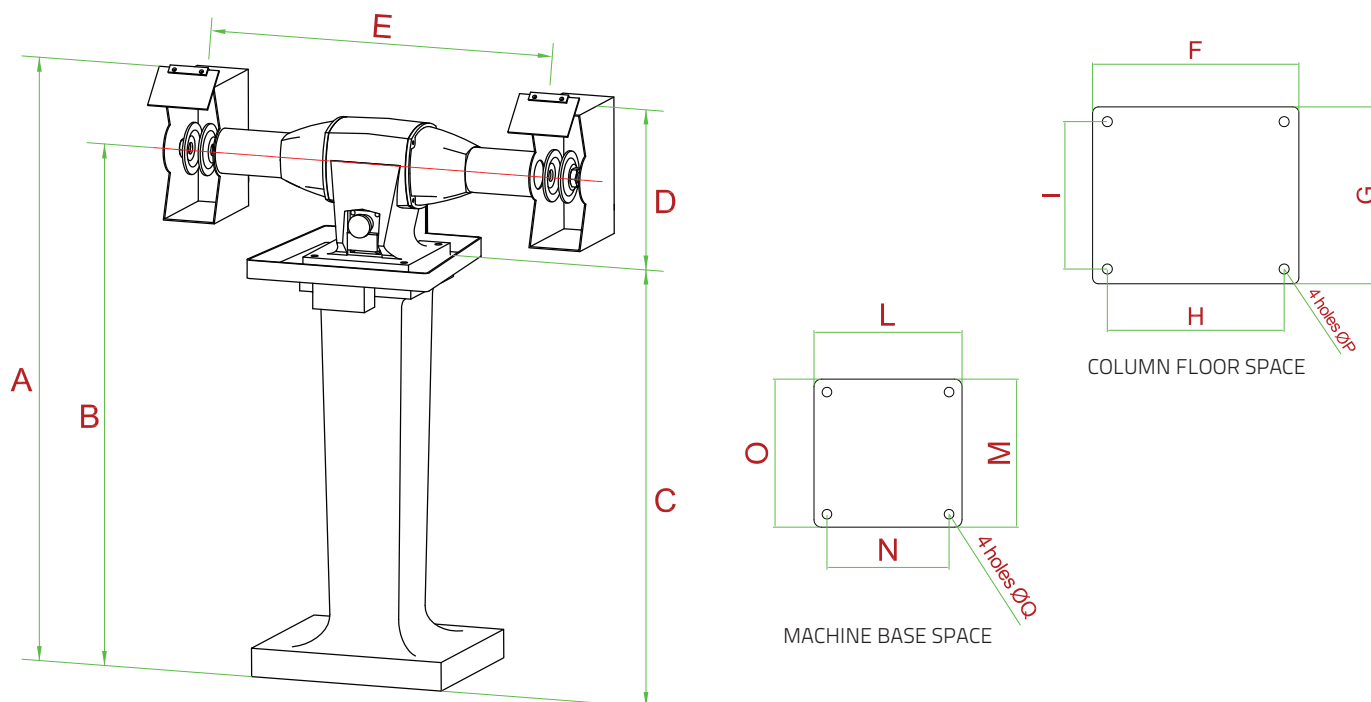

TYPE	POWER		A mm	B mm	C mm	D mm	E mm	F mm	G mm	H mm	I mm	L mm	M mm	N mm	O mm	ØP mm	ØQ mm
	KW	HP															
PP/3	0,75	1	1000	880	715	285	600	300	250	265	205	180	180	155	155	14	10
PP/4	0,75	1	1010	895	710	300	670	350	300	300	250	200	200	165	165	17	12
PP/5	1,12	1,5	1010	895	710	300	680	350	300	300	250	200	200	165	165	17	12
PP/6	1,12	1,5	1050	900	710	340	850	350	350	285	295	210	210	170	170	17	12
PP/7	1,49	2	1050	900	710	340	860	350	350	285	295	210	210	170	170	17	12
PP/8	2,24	3	1105	900	710	395	900	350	350	285	295	210	210	170	170	17	12
PP/9	2,24	3	1110	885	650	460	1000	400	390	350	350	260	260	210	210	17	12
PP/10	2,98	4	1110	885	650	460	1010	400	390	350	350	260	260	210	210	17	12
PP/11	3,73	5	1110	885	650	460	1015	400	390	350	350	260	260	210	210	17	12

Brushes excluded. Illustrations may include optional accessories. Stefani S.r.l. reserves the right to make changes or improvements without notice.

