



DEBURRING MACHINE at constant speed

For wheels diameter 600 mm



Via Villorosi 71 - 20029 Turbigo MI
P.IVA e C.F. 11336420150
Tel. +39.0331.899144
Fax +39.0331.890178
info@stefanisrl.it - www.stefanisrl.it

DEBURRING MACHINE

at constant speed

For wheels
diameter 600 mm

DESIGNED FOR INDUSTRIAL AND HEAVY USE IN THE FIELD OF DEBURRING CASTINGS IN CAST IRON OR STEEL: THE SPEED OF USE REMAINS CONSTANT AT 63 M/SECOND EVEN AS THE GRINDING WHEEL DIAMETER CHANGES DUE TO WEAR.





Technical features:

- Strong thickness electro-welded structure, to ensure maximum stability and the absence of vibrations
- Motor with 4 kW power to work in continuous operation with maximum friction pressure 24 hours a day without any maintenance problems
- Grinding wheel diameter mm 600 and **constant rotation speed of 63 m per second, which significantly improves grinding performance while maintaining a constant cutting effort and consequent grinding wheel wear**
- Mechanical components manufactured and machined in-house to guarantee Stefani's Made in Italy quality
- Hardened and case-hardened cartridge spindle: the cartridge system allows rapid replacement of the spindle during overhauls
- Clamping flanges turned from billet and with a larger diameter than required by the standard, with 3 balancing sectors
- Safety guard made of high-tight steel plate, equipped with suction connections
- Extreme safety for the operator: **the casing lowers simultaneously with the adjustment of the workpiece support surface as the diameter of the abrasive wheel decreases**
- Generously dimensioned workpiece support plate with replaceable overplates
- Control panel with start/stop/emergency buttons
- Anti-reset function, 24-Volt electrical equipment and thermal magnetic protection
- Compliant with EC standards.

Optional:

- Exhauster.

SINGLE-SEAT DEBURRING MACHINE TECHNICAL DATA

MODEL	Hp	Kw		 m per second	 mm	 Kg
SM60/VE	5,5	4	3-phase- 50 Hz	63	600X60 f.127	800

OVERALL DIMENSIONS - SINGLE-SEAT DEBURRING MACHINE IN CONTINUOUS OPERATION

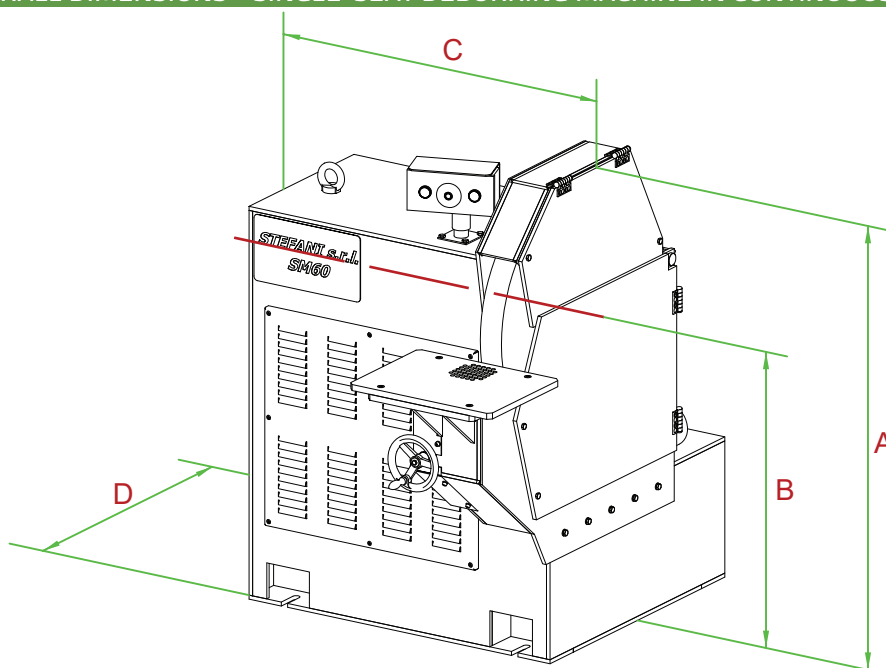

TYPE	A mm	B mm	C mm	D mm
SM60/VE	1200	850	1005	1250

Grinding wheels excluded. Illustrations may include optional accessories. Stefani S.r.l. reserves the right to make changes or improvements without notice.

