



CE

DEBURRING MACHINE
with independent grinding wheels
For grinding wheels with a diameter of 500 mm and 600 mm



Via Villorosi 71 - 20029 Turbigo MI
P.IVA e C.F. 11336420150
Tel. +39.0331.899144
Fax +39.0331.890178
info@stefanisrl.it - www.stefanisrl.it

DEBURRING MACHINE

with independent grinding wheels

For grinding wheels with a diameter of 500 mm and 600 mm

DESIGNED FOR INDUSTRIAL AND HEAVY USE IN THE DEBURRING SECTOR OF CAST IRON OR STEEL CASTINGS: THE TOTAL INDEPENDENCE OF THE TWO ABRASIVE WHEELS OFFERS THE USER GREAT FLEXIBILITY IN ITS USE.





Technical features:

- Strong thickness electro-welded structure, to ensure maximum stability and the absence of vibration
- Two independent motors with 4 kW + 4 kW power, to work in continuous operation with maximum friction pressure 24 hours a day without any maintenance problems
- Grinding wheel diameter mm 500 or mm 600 and rotation speed of 33/50/60 m per second depending on the model chosen
- Mechanical components manufactured and machined in-house to guarantee Stefani's Made in Italy quality
- Spindle shafts with cartridge system: this system allows rapid spindle replacement during maintenance
- Clamping flanges turned from billet and with a larger diameter than required by the standard
- Safety guards made of high-strength sheet steel, equipped with suction connections
- Generously dimensioned workpiece support plate
- Two independent control panels with start/stop/emergency buttons
- Anti-reset function, 24-Volt electrical equipment and thermal magnetic protection
- Compliant with EC standards

Optional:

- Exhauster
- Height-adjustable workpiece support, so that you can always work at the centre of the grinding wheel regardless of the size of the workpiece

SM CONTINUOUS OPERATION DEBURRING MACHINE TECHNICAL DATA

MODEL	Hp	Kw		 m per second	 mm	 Kg
SM50/A	5,5 + 5,5	4 + 4	3-phase – 50 Hz	33	500X60 f.50	940
SM50/B	5,5 + 5,5	4 + 4	3-phase – 50 Hz	50	500X60 f.127	950
SM50/C	5,5 + 5,5	4 + 4	3-phase – 50 Hz	60	500X60 f.127	950
SM60	5,5 + 5,5	4 + 4	3-phase – 50 Hz	60	600X60 f.127	1000

OVERALL DIMENSIONS DEBURRING MACHINE WITH INDEPENDENT GRINDING WHEELS

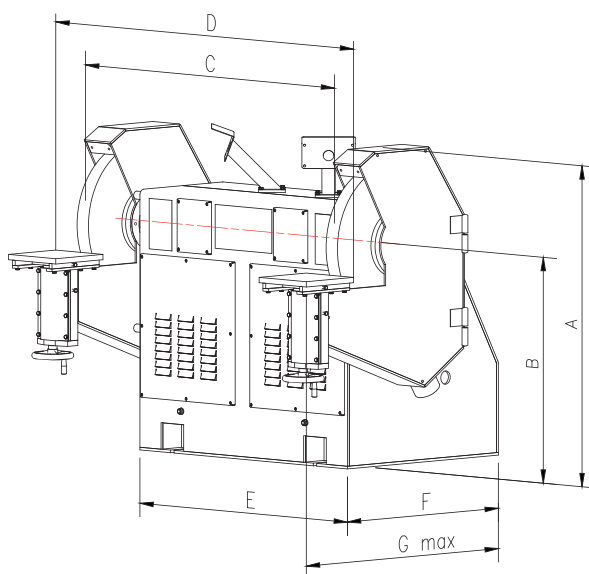

TIPO	A mm	B mm	C mm	D mm	E mm	F mm	G mm
SM50/A	1200	850	1320	1580	1100	800	1280
SM50/B	1200	850	1320	1580	1100	800	1280
SM50/C	1200	850	1320	1580	1100	800	1280
SM60	1250	850	1320	1580	1100	800	1330

Grinding wheels excluded. Illustrations may include optional accessories. Stefani S.r.l. reserves the right to make changes or improvements without notice.

